

Design/System/Construction/Assembly Usage Disclaimer

- Authorities Having Jurisdiction should be consulted in all cases as to the particular requirements covering the installation and use of UL Certified products, equipment, system, devices, and materials.
- Authorities Having Jurisdiction should be consulted before construction.
- Fire resistance assemblies and products are developed by the design submitter and have been investigated by UL for compliance with applicable requirements. The published information cannot always address every construction nuance encountered in the field.
- When field issues arise, it is recommended the first contact for assistance be the technical service staff provided by the product manufacturer noted for the design. Users of fire resistance assemblies are advised to consult the general Guide Information for each product category and each group of assemblies. The Guide Information includes specifics concerning alternate materials and alternate methods of construction.
- Only products which bear UL's Mark are considered Certified.

BXUV - Fire Resistance Ratings - ANSI/UL 263 Certified for United States

BXUV7 - Fire Resistance Ratings - CAN/ULC-S101 Certified for Canada

See General Information for Fire-resistance Ratings - ANSI/UL 263 Certified for United States Design Criteria and Allowable Variances

See General Information for Fire Resistance Ratings - CAN/ULC-S101 Certified for Canada Design Criteria and Allowable Variances

Design No. **U403**

August 4, 2023

Nonbearing Wall Rating — 2 HR.

* Indicates such products shall bear the UL or cUL Certification Mark for jurisdictions employing the UL or cUL Certification (such as Canada), respectively.

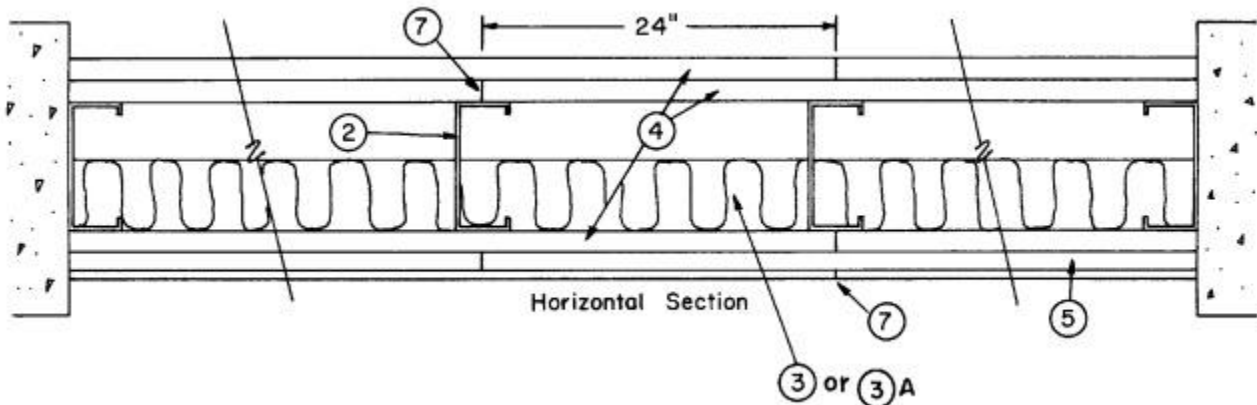

1. **Floor and Ceiling Runners** — Channel shaped, 1-1/4 in. wide by 3-5/8 in. deep, fabricated from min 0.020 in. thick (25 gauge) galv steel, attached to floor and ceiling with fasteners spaced 24 in. O.C.

1A. **Framing Members*** — **Floor and Ceiling Runner** — Not Shown — In lieu of Item 1 — For use with Item 2A, proprietary channel shaped runners, 1-1/4 in. wide by min 3-5/8 in. deep fabricated from min 0.018 in. thick galv steel, attached to floor and ceiling with fasteners spaced 24 in. OC max.

CEMCO, LLC — Viper20™Track

MARINO/WARE, DIV OF WARE INDUSTRIES INC — Viper20™Track

IMPERIAL MANUFACTURING GROUP INC — Viper20™ Track

1B. Framing Members* — Floor and Ceiling Runner — Not Shown — In lieu of Item 1 — For use with Item 2B, channel shaped runners, 1-1/4 in. deep by min 3-5/8 in. wide fabricated from min 0.018 in. thick galv steel, attached to floor and ceiling with fasteners spaced 24 in. OC max.

CLARKDIETRICH BUILDING SYSTEMS — CD ProTRAK

DMFCWBS L L C — ProTRAK

MBA METAL FRAMING — ProTRAK

RAM SALES L L C — Ram ProTRAK

STEEL STRUCTURAL PRODUCTS L L C — Tri-S ProTRAK

1C. Framing Members* — Floor and Ceiling Runner — Not Shown — In lieu of Item 1 — For use with Item 2C, proprietary channel shaped runners, 1-1/4 in. wide by min 3-5/8 in. deep fabricated from min 0.018 in. thick galv steel, attached to floor and ceiling with fasteners spaced 24 in. OC max.

MARINO/WARE, DIV OF WARE INDUSTRIES INC — Viper20™Track

1D. Framing Members* — Floor and Ceiling Runner — Not Shown — In lieu of Item 1 — For use with Item 2D, channel shaped runners, 1-1/4 in. deep by min 3-5/8 in. wide fabricated from min 0.018 in. thick galv steel, attached to floor and ceiling with fasteners spaced 24 in. OC max.

TELLING INDUSTRIES L L C — TRUE-TRACK™

1E. Framing Members* — Floor and Ceiling Runner — Not Shown — In lieu of Item 1 — For use with Item 2F, channel shaped runners, 1-1/4 in. deep by min 3-5/8 in. wide fabricated from min 0.018 in. thick galv steel, attached to floor and ceiling with fasteners spaced 24 in. OC max.

RESCUE METAL FRAMING, L L C — AlphaTRAK

1F. Framing Members* — Floor and Ceiling Runner — Not Shown — In lieu of Item 1 — For use with Item 2G, proprietary channel shaped runners, 1-1/4 in. wide by min 3-5/8 in. deep fabricated from min 0.020 in. thick galv steel, attached to floor and ceiling with fasteners spaced 24 in. OC max.

CRACO MFG INC — SmartTrack20™

STUDCO BUILDING SYSTEMS — CROCSTUD Track

1G. Framing Members* — Floor and Ceiling Runner — Not Shown — In lieu of Item 1 — For use with Item 2H, proprietary channel shaped runners, 1-1/4 in. wide by min. 3-5/8 in. deep fabricated from min 0.019 in. thick galv steel, attached to floor and ceiling with fasteners spaced 24 in. OC.

PANEL REY S A – SUPRA Track 20EQ/19 mil

2. Steel Studs — Channel shaped, 3-5/8 in. deep, min 0.020 in. thick (25 gauge) galv steel. Studs 3/8 in. less in lengths than assembly heights.

2A. Framing Members* — Steel Studs — Not Shown — In lieu of Item 2 — For use with Item 1A, proprietary channel shaped steel studs, 1-1/4 in. wide by min 3-5/8 in. deep fabricated from min 0.018 in. thick galv steel. Studs cut 3/8 in. less in length than assembly height.

CEMCO, LLC — Viper20™

MARINO/WARE, DIV OF WARE INDUSTRIES INC — Viper20™

IMPERIAL MANUFACTURING GROUP INC — Viper20™

2B. Framing Members* — Steel Studs — Not Shown — In lieu of Item 2 — For use with Item 1B, channel shaped steel studs, min 3-5/8 in. wide fabricated from min 0.018 in. thick galv steel, spaced max 24 in. OC. Studs cut 3/8 in. less in length than assembly height.

CLARKDIETRICH BUILDING SYSTEMS — CD ProSTUD

DMFCWBS L L C — ProSTUD

MBA METAL FRAMING — ProSTUD

RAM SALES L L C — Ram ProSTUD

STEEL STRUCTURAL PRODUCTS L L C — Tri-S ProSTUD

2C. Framing Members* — Steel Studs — Not Shown — In lieu of Item 2 — For use with Item 1C, proprietary channel shaped steel studs, 1-1/4 in. wide by min 3-5/8 in. deep fabricated from min 0.018 in. thick galv steel. Studs cut 3/8 in. less in length than assembly height.

MARINO/WARE, DIV OF WARE INDUSTRIES INC — Viper20™

2D. Framing Members* — Steel Studs — Not Shown — In lieu of Item 2 — For use with Item 1D, proprietary channel shaped steel studs, 1-1/4 in. wide by min 3-5/8 in. deep fabricated from min 0.020 in. thick galv steel. Studs cut 3/8 in. less in length than assembly height.

TELLING INDUSTRIES L L C — TRUE-STUD™

2E. Framing Members* — Steel Studs — As an alternate to Item 2 — For use with Item 1A (3-5/8 in. wide track), channel shaped studs, fabricated from min 25 MSG corrosion-protected steel, 1-1/4 in. wide by 3-5/8 in. deep, spaced a max of 24 in. OC. Studs to be cut 3/8 to 3/4 in. less than assembly height.

MARINO/WARE, DIV OF WARE INDUSTRIES INC — StudRite™

2F. Framing Members* — Steel Studs — Not Shown — In lieu of Item 2 — For use with Item 1E, channel shaped steel studs, min 3-5/8 in. wide fabricated from min 0.018 in. thick galv steel, spaced max 24 in. OC. Studs cut 3/8 in. less in length than assembly height.

RESCUE METAL FRAMING, L L C — AlphaSTUD

2G. Framing Members* — Steel Studs — Not Shown — In lieu of Item 2 — For use with Item 1F, proprietary channel shaped steel studs, 1-1/4 in. wide by min 3-5/8 in. deep fabricated from min 0.020 in. thick galv steel. Studs cut 3/8 in. less in length than assembly height.

CRACO MFG INC — SmartStud20™

STUDCO BUILDING SYSTEMS — CROCSTUD

2H. Framing Members* — Steel Studs — Not Shown — In lieu of Item 2 – For use with Item 1G, proprietary channel shaped steel studs, min 1-1/4 in. wide by min 3-5/8 in. deep with 1/4 in. return lips fabricated from min 0.019 in. thick galv steel. Studs cut 3/8 in. less in length than assembly height.

PANEL REY S A – SUPRA Stud 20EQ/19 mil

3. Batts and Blankets* — Optional — Mineral wool or glass fiber insulation, partially or completely filling stud cavity.

CERTAINTED CORP

INDUSTRIAL INSULATION GROUP L L C — Type SAFB

JOHNS MANVILLE — Type SAFB

JOHNS MANVILLE

KNAUF INSULATION LLC

KNAUF INSULATION LLC

MANSON INSULATION INC

OWENS CORNING

ROCKWOOL — Type AFB, min. density 1.69 pcf / 27.0 kg/m³

3A. Fiber, Sprayed* — As an alternate to Batts and Blankets (Item 3) — (100% Borate Formulation) — Spray applied cellulose material. The fiber is applied with water to completely fill the enclosed cavity in accordance with the application instructions supplied with the product with a nominal dry density of 2.7 lb/ft³. Alternate Application Method: The fiber is applied without water or adhesive at a nominal dry density of 3.5 lb/ft³, in accordance with the application instructions supplied with the product.

Applegate Greenfiber Acquisition LLC — Insulmax and SANCTUARY for use with wet or dry application.

3B. Fiber, Sprayed* — As an alternate to Batts and Blankets (Item 3) and Item 3A - Spray applied cellulose insulation material. The fiber is applied with water to interior surfaces in accordance with the application instructions supplied with the product.

Applied to completely fill the enclosed cavity. Minimum dry density of 4.3 pounds per cubic ft.

NU-WOOL CO INC — Cellulose Insulation

3C. **Fiber, Sprayed*** — As an alternate to Batts and Blankets (Item 3) - Spray applied cellulose fiber. The fiber is applied with water to completely fill the enclosed cavity in accordance with the application instructions supplied with the product. The minimum dry density shall be 4.30 lbs/ft³.

INTERNATIONAL CELLULOSE CORP — Celbar-RL

3D. Deleted.

4. **Gypsum Board*** — 5/8 in. thick, 48 in. wide sheets. Inner layer applied vertically, attached to studs and floor and ceiling runners with 0.127 in. diam by 1 in. long self-drilling, self-tapping Phillips head steel screws spaced 32 in. O.C., joints located over studs. Outer layer on one side applied vertically and attached to studs and runners with 1-5/8 in. long self-drilling, self-tapping steel screws spaced 12 in. O.C. along ends and edges of boards and 24 in. O.C. in the field. Outer layer joints offset from inner layer joints and located over studs.

AMERICAN GYPSUM CO — Type AG-C

CERTAINTED GYPSUM INC — Type C or SF-3

GEORGIA-PACIFIC GYPSUM L L C — Types DAPC, TG-C

THAI GYPSUM PRODUCTS PCL — Type C

5. **Gypsum Board*** — 1/2 in. thick, 48 in. wide sheets. Sheets applied vertically and attached to studs and runners with 1-5/8 in. long self-drilling, self-tapping steel screws spaced 12 in. O.C. along ends and edges of boards and 24 in. O.C. in the field. Joints offset from inner layer joints.

AMERICAN GYPSUM CO — Type AG-C

CERTAINTED GYPSUM INC — Type C

GEORGIA-PACIFIC GYPSUM L L C — Types DAPC, TG-C

THAI GYPSUM PRODUCTS PCL — Type C

7. **Joints — (Not Shown)** — Outer layer joints on both sides of wall (finish layer only) covered with paper tape and joint compound. Screw heads covered with joint compound.

*** Indicates such products shall bear the UL or cUL Certification Mark for jurisdictions employing the UL or cUL Certification (such as Canada), respectively.**

Last Updated on 2023-08-04

The appearance of a company's name or product in this database does not in itself assure that products so identified have been manufactured under UL Solutions' Follow - Up Service. Only those products bearing the UL Mark should be considered to be Certified and covered under UL Solutions' Follow - Up Service. Always look for the Mark on the product.

UL Solutions permits the reproduction of the material contained in Product iQ subject to the following conditions: 1. The Guide Information, Assemblies, Constructions, Designs, Systems, and/or Certifications (files) must be presented in their entirety and in a non-misleading manner, without any manipulation of the data (or drawings). 2. The statement "Reprinted from Product iQ with permission from UL Solutions" must appear adjacent to the extracted material. In addition, the reprinted material must include a copyright notice in the following format: "©2023 UL LLC."